

# VHF/UHF DUAL BAND COLLINEAR BASE STATION ANTENNA

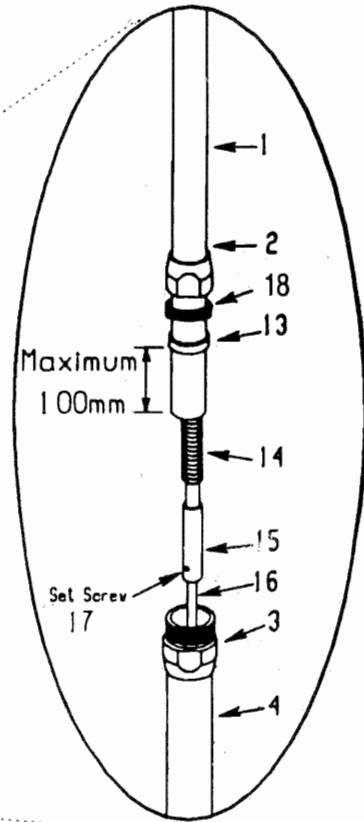
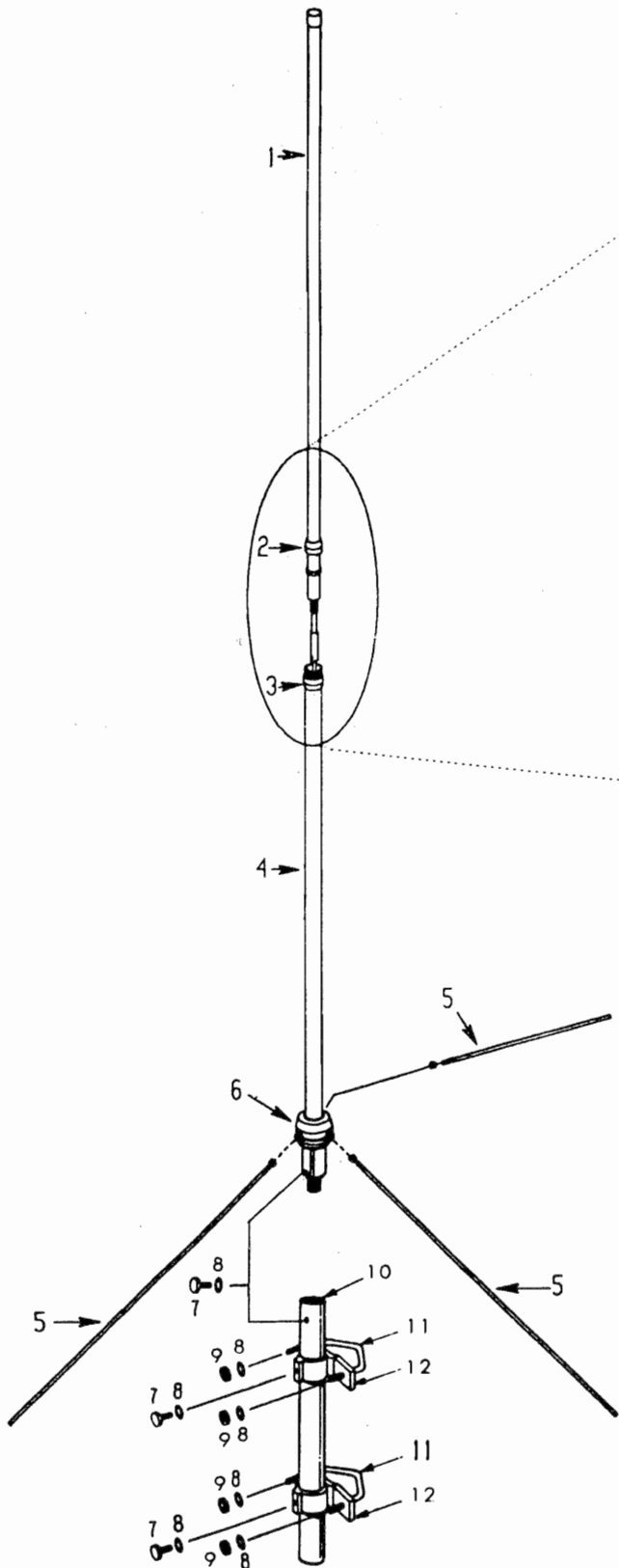

Parts List		
Ref#	Description	Qty
1	Upper Outer Shell	1
2	Upper Outer Shell Joint	1
3	Lower Outer Shell Joint	1
4	Lower Outer Shell	1
5	Radial Element with Lock Nut	3
6	Matching Coil	1
7	Locking Screw	3
8	Lockwasher	7
9	Nut	4
10	Support Pipe	1
11	V - Bolt	2
12	Bracket	2
13	Gasket	1
14	Upper Radiator Element	1
15	Element Joint	1
16	Lower Radiator Element	1
17	Set Screw	1
18	Gasket Cover	1

# DUAL BAND BASE STATION ANTENNA

## Specifications

GAIN	6 dB (2 M) or 8 dB (70 cm) better than quarter wave antenna
VSWR	Less than 1.5:1
FREQUENCY RANGE	144 - 148 (2 M) and 430 - 450 MHz (70 cm)
POLARIZATION	Vertical
IMPEDANCE	50 Ohm
CONFIGURATION	5/8 wave 2 element (2 M) 5/8 wave 4 element (70 cm)
POWER CAPACITY	200 Watts
CONNECTOR	SO-239

## Assembly

1. Refer to drawing (over). Install upper radiator element (14) onto lower radiator element (16) by inserting element joint (15) fully onto lower radiator element and tightening set screw (17) securely with allen wrench (not supplied).
2. Slide upper outer shell joint (2) gasket cover (18) and gasket (13) onto upper outer shell (1). The gasket must be positioned no more than 100 mm (3 15/16 inches) from the bottom of upper outer shell as shown. Slide this assembly over upper radiator element into lower outer shell joint (3) and lower outer shell (4). Thread upper outer shell joint onto lower outer shell joint and tighten securely with wrench on flat sides of outer shell joints.
3. Screw the three radial elements (5) into threaded holes at the bottom of matching coil (6) and finger tighten. Secure by tightening lock nuts with wrench.
4. Secure support pipe (10) to mounting pole (not included) in desired location using brackets (12), v-bolts (11), locking screws (7), lock washers (8), and either self locking nuts or nuts (9) and lock washers (8) supplied. Tighten securely with wrench.
5. Install PL-259 connector (not included) onto coaxial cable from radio and run it up through support pipe (10) and screw PL-259 tightly onto SO-239 connector at base of matching coil (6). Lower assembled antenna into support pipe with open threaded hole turned so that it will align with hole in support pipe for locking screw. Thread locking screw (7) with lock washer (8) installed into hole and tighten securely with wrench.

## Adjustment

No adjustment is necessary. Your **UVS-200** is pre-aligned at the factory for 144 - 148 MHz and 430 - 450 MHz.